

Changeover valve with gland seal

ARI-Changeover valve - 3-way form with flanges

- EN ISO 15848-1 / TA - Luft (optional)
TÜV-Test-No. 973-10675245-10 A

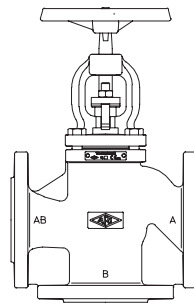

Grey cast iron

Fig. 017

Page 2

ARI-Changeover valve - 3-way form with flanges

- TRB 801 Annex II No. 45
- EN ISO 15848-1 / TA - Luft (optional)
TÜV-Test-No. 973-10675245-10 A
- Bonnet top with threaded bushing
- Flap-type screws

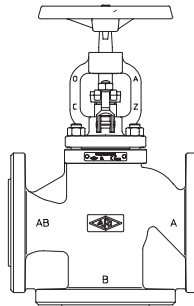

Cast steel

Fig. 017

Page 3

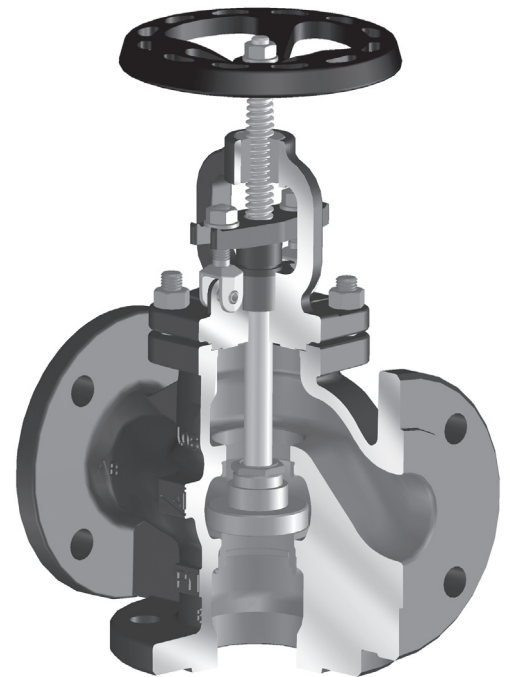

Fig. 017

Features:

- Proven technology
- Solid plug made of stainless material
- Solid stem made of stainless material
- Solid seat made of stainless material
- Stem with roll hardened thread
- Burnished stem
- High-tensile gland packing
- Favourable zeta-values also for small nominal diameters

Changeover valve - 3-way with flanges and gland seal (Grey cast iron, SG iron)

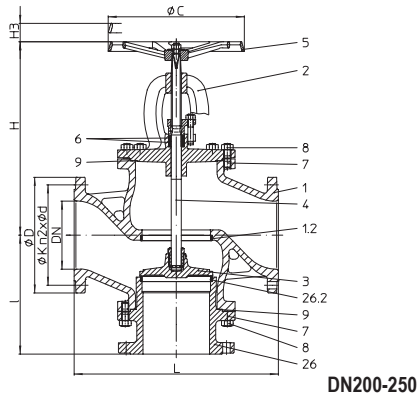
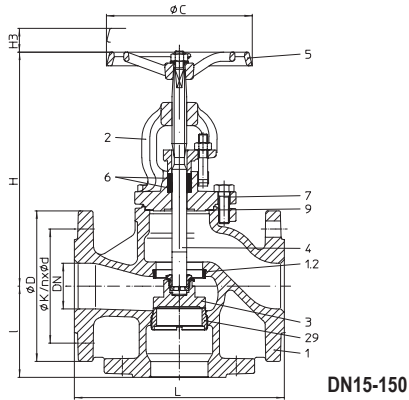

Figure	Nominal pressure	Material	Nominal diameter
12.017	PN 16	EN-JL1040	DN15-250

Test:	<ul style="list-style-type: none"> • optional: EN ISO 15848-1 / TA - Luft TÜV-Test-No. 973-10675245-10 A
-------	---

Observe max. differential pressure ! (refer to page 4)

Parts			
Pos.	Sp.p.	Description	Fig. 12.017
1		Body	EN-JL1040, EN-GJL-250
1.2		Seat ring	X20Cr13+QT, 1.4021+QT
2		Bonnet	EN-JL1040, EN-GJL-250
3	x	Plug	X20Cr13+QT, 1.4021+QT
4	x	Stem	X20Cr13+QT, 1.4021+QT (burnished)
5		Handwheel	EN-JL1040, EN-GJL-250 (FE 13 Epoxid-coating)
6	x	Packing ring	Pure graphite
7		Hexagon screws	DN15-100: 5.6
7		Stud	DN125-250: 25CrMo4, 1.7218
8		Hexagon nut	DN125-250: C35E, 1.1181
9	x	Gasket	Pure graphite (CrNi laminated with graphite)
26		Connecting piece	DN200-250: GP240GH+N, 1.0619+N
26.2		Seat ring	DN200-250: X20Cr13+QT, 1.4021+QT
29		Seat ring	DN15-150: X20Cr13+QT, 1.4021+QT
L Spare parts			

DN	15	20	25	32	40	50	65	80	100	125	150	200	250
----	----	----	----	----	----	----	----	----	-----	-----	-----	-----	-----

Face-to-face dimension FTF series 1 according to DIN EN 558													Standard-flange dimensions refer to page 4	
L	(mm)	130	150	160	180	200	230	290	310	350	400	480	600	730

Dimensions														
	(mm)	65	70	75	80	90	100	120	130	150	200	210	350	440
I	(mm)	65	70	75	80	90	100	120	130	150	200	210	350	440
H	(mm)	209	209	220	242	263	257	320	351	400	458	528	546	646
H3 (Travel)	(mm)	20	20	20	20	20	20	30	30	30	50	50	90	90
ØC	(mm)	140	140	140	140	160	160	180	200	225	250	400	520	520
Kvs-value (port A - AB)	(m³/h)	5,9	7,6	9,5	18,8	19,4	37,4	79,5	116	176	256	356	630	1000
Kvs-value (port B - AB)	(m³/h)	9,3	17,9	20,2	29,3	40,1	68,2	107	155	224	395	520	700	1100
Zeta-value (port A - AB)	--	2,4	4,5	6,9	4,7	10,9	7,1	4,5	4,8	5,2	5,9	6,3	6,7	6
Zeta-value (port B - AB)	--	0,9	0,8	1,5	1,9	2,5	2,1	2,5	2,7	3,2	2,5	3	5	4,9
Zeta-value ... range of tolerance for Kvs-values acc. to VDI/VDE 2173														

Weights														
12.017	(kg)	5,6	6,8	7,9	10,9	14,6	18	26,2	37	54	84,2	124	155	290

Information / restriction of technical rules need to be observed!

Operating and installation instructions can be downloaded at www.ari-armaturen.com.

ARI-Valves of EN-JL1040 are not allowed to be operated in systems acc. to TRD 110.

The engineer, designing a system or a plant, is responsible for the selection of the correct valve.

Resistance and fitness must be verified (contact manufacturer for information, refer to Product overview and Resistance list).

Changeover valve - 3-way with flanges and gland seal (Cast steel)

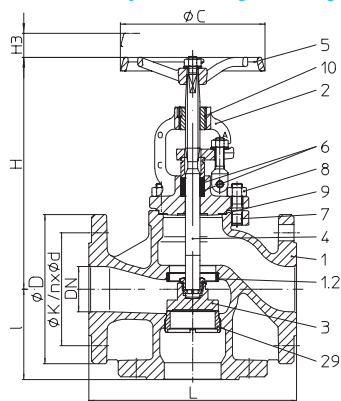

DN15-150

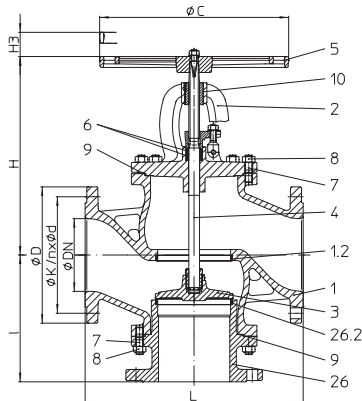

DN200-250

Figure	Nominal pressure	Material	Nominal diameter
34.017	PN 25	1.0619+N	DN15-250
35.017	PN 40	1.0619+N	DN15-250

Test:	<ul style="list-style-type: none"> optional: EN ISO 15848-1 / TA - Luft TÜV-Test-No. 973-10675245-10 A
-------	---

Observe max. differential pressure! (refer to page 4)

Parts			
Pos.	Sp.p.	Description	Fig. 34./35.017
1		Body	GP240GH+N, 1.0619+N
1.2		Seat ring	DN ≤50: X20Cr13+QT, 1.4021+QT / DN >50: G19 9 Nb Si, 1.4551
2		Bonnet	GP240GH+N, 1.0619+N
3	x	Plug	X20Cr13+QT, 1.4021+QT
4	x	Stem	X20Cr13+QT, 1.4021+QT (burnished)
5		Handwheel	EN-JL1040, EN-GJL-250 (FE 13 Epoxid-coating)
6	x	Packing ring	Pure graphite
7		Stud	25CrMo4, 1.7218
8		Hexagon nut	C35E, 1.1181
9		Gasket	Pure graphite (CrNi laminated with graphite)
10	x	Insert nuts	11SMn30+C, 1.0715+C
26		Connecting piece	DN200-250: GP240GH+N, 1.0619+N
26.2		Seat ring	DN200-250: X20Cr13+QT, 1.4021+QT
29		Seat ring	DN15-150: X20Cr13+QT, 1.4021+QT
L Spare parts			

DN	15	20	25	32	40	50	65	80	100	125	150	200	250
----	----	----	----	----	----	----	----	----	-----	-----	-----	-----	-----

Face-to-face dimension FTF series 1 according to DIN EN 558												Standard-flange dimensions refer to page 4		
L	(mm)	130	150	160	180	200	230	290	310	350	400	480	600	730

Dimensions														
I	(mm)	65	70	75	80	90	100	120	130	150	200	210	350	440
H	(mm)	209	209	220	242	263	257	320	351	400	458	528	546	646
H3 (Travel)	(mm)	20	20	20	20	20	20	30	30	30	50	50	90	90
ØC	(mm)	140	140	140	140	160	160	180	200	225	250	400	520	520
Kvs-value (port A - AB)	(m³/h)	5,9	7,6	9,5	18,8	19,4	37,4	79,5	116	176	256	356	630	1000
Kvs-value (port B - AB)	(m³/h)	9,3	17,9	20,2	29,3	40,1	68,2	107	155	224	395	520	700	1100
Zeta-value (port A - AB)	--	2,4	4,5	6,9	4,7	10,9	7,1	4,5	4,8	5,2	5,9	6,3	6,7	6
Zeta-value (port B - AB)	--	0,9	0,8	1,5	1,9	2,5	2,1	2,5	2,7	3,2	2,5	3	5	4,9

Zeta-value ... range of tolerance for Kvs-values acc. to VDI/VDE 2173

Weights														
34.017	(kg)	6,1	7,4	8,5	11,8	15,8	19,4	28,2	39,8	58,1	90,6	133,5	167	320
35.017	(kg)	6,1	7,4	8,5	11,8	15,8	19,4	28,2	39,8	58,1	90,6	133,5	177	338

Information / restriction of technical rules need to be observed!

Operating and installation instructions can be downloaded at www.ari-armaturen.com.

The engineer, designing a system or a plant, is responsible for the selection of the correct valve.

Resistance and fitness must be verified (contact manufacturer for information, refer to Product overview and Resistance list).

DN	15	20	25	32	40	50	65	80	100	125	150	200	250
----	----	----	----	----	----	----	----	----	-----	-----	-----	-----	-----

Standard-flange dimensions			Flanges acc. to DIN EN 1092-1/-2 (Flange holes / -thickness tolerances acc. to DIN 2533/2544/2545)												
PN16	ØD	(mm)	95	105	115	140	150	165	185	200	220	250	285	340	405
	ØK	(mm)	65	75	85	100	110	125	145	160	180	210	240	295	355
	n x Ød	(mm)	4x14	4x14	4x14	4x18	4x18	4x18	4x18 ¹⁾	8x18	8x18	8x18	8x22	12x22	12x26
PN25	ØD	(mm)	95	105	115	140	150	165	185	200	235	270	300	360	425
	ØK	(mm)	65	75	85	100	110	125	145	160	190	220	250	310	370
	n x Ød	(mm)	4x14	4x14	4x14	4x18	4x18	4x18	8x18	8x18	8x22	8x26	8x26	12x26	12x30
PN40	ØD	(mm)	95	105	115	140	150	165	185	200	235	270	300	375	450
	ØK	(mm)	65	75	85	100	110	125	145	160	190	220	250	320	385
	n x Ød	(mm)	4x14	4x14	4x14	4x18	4x18	4x18	8x18	8x18	8x22	8x26	8x26	12x30	12x33

¹⁾ also with 8 bore holes acc. to DIN EN 1092-1/-2 possible.

Pressure-temperature-ratings Intermediate values for max. permissible operational pressures can be determined by linear interpolation of the given temperature / pressure chart.

acc. to DIN EN 1092-2			-60°C to <-10°C ¹⁾	-10°C to 120°C	150°C	200°C	250°C	300°C	350°C	400°C	450°C
EN-JL1040	16	(bar)	--	16	14,4	12,8	11,2	9,6	--	--	--

acc. to manufacturers standard			-60°C to <-10°C ¹⁾	-10°C to 120°C	150°C	200°C	250°C	300°C	350°C	400°C	450°C
1.0619+N	25	(bar)	18,7	25	23,9	22	20	17,2	16	14,8	8,2
1.0619+N	40	(bar)	30	40	38,1	35	32	28	25,7	23,8	13,1

¹⁾ Studs and nuts made of A4-70 (at temperatures below -10°C)

Flow

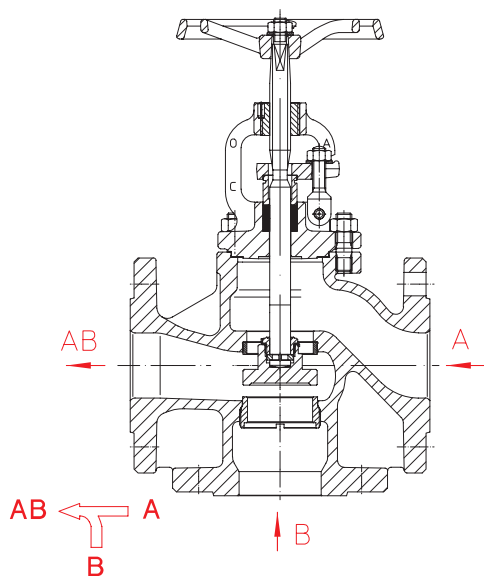

Function: 3-way mixing valve

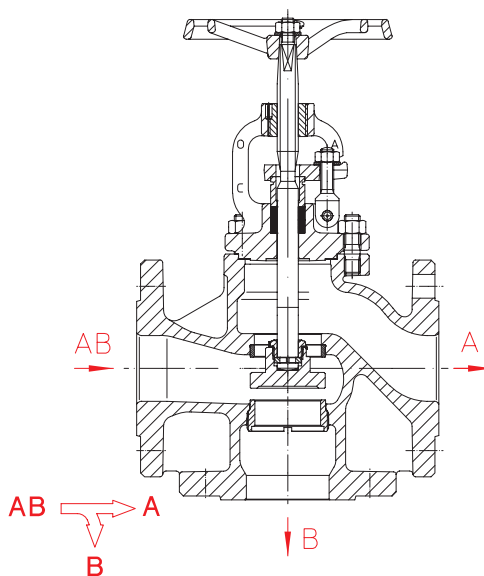

Function: 3-way diverting valve

Please indicate when ordering:

- Figure-No.
- Nominal pressure
- Nominal diameter

Example:

Figure 35.017;
Nominal pressure PN40;
Nominal diameter DN100

Max. Operating range		125	150	200	250
DN					
max. differential pressure (ΔP)	(bar)	25	21	14	9